

SP-10G Data Sheet

Flow Versus Pressure

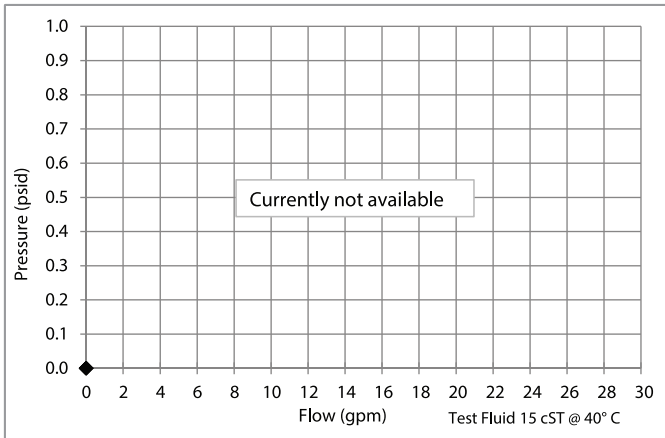

General Construction and Operating Conditions

Media	10 μ Microglass
Max. Working Pressure	175psi
Max. Flow Rate	22gpm
Terminal Differential Pressure	25psid

Reference Performance Values

$B_{<4} = 2$	$B_4 = 3.15$
$B_{6.6} = 10$	$B_6 = 7.22$
$B_{9.9} = 75$	$B_{14} = 20.2$
$B_{10.4} = 100$	
$B_{11.4} = 200$	

Retention Capacity - N/A

Average Filtration Efficiency

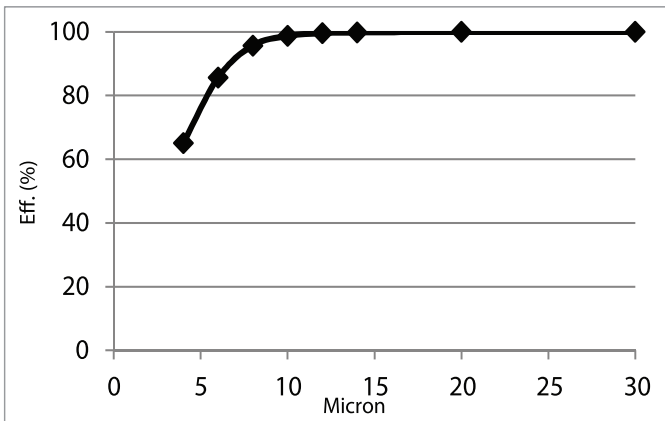

Reference Dimensions

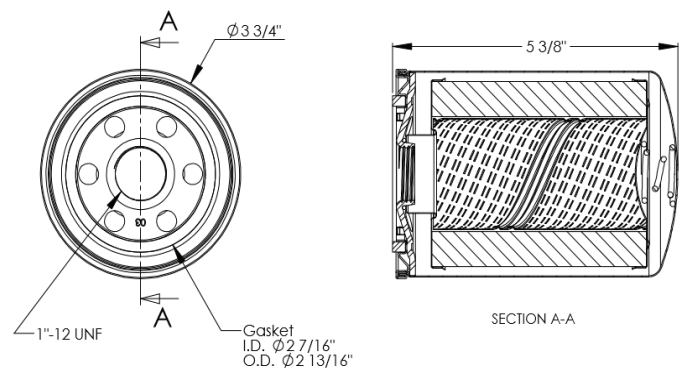

Products are not to be used in aviation applications. All product data and statements are indicative of typical properties and characteristics obtainable. This data sheet is to be used as a guide and not as a specification sheet. Ohio Fabricators Company makes no representation or warranty except as otherwise noted. Technical data subject to change without notice.